



**mimio**<sup>®</sup>

# Choosing and Installing a Whiteboard for a Touch Projector

Stevan Vigneaux  
Director of Product Management, Mimio







# Choosing and Installing a Whiteboard for a Touch Projector

## Introduction

Touch control for interactive projectors is very attractive, particularly for young children, whose manual dexterity is not highly developed. Many students are already comfortable with touch control from using smartphones and tablets, and it's easy to learn. As a result, touch projectors are gaining wide acceptance in classrooms.

It is tempting to imagine that installing a touch projector is as simple and easy as installing a non-interactive or pen-interactive projector. However, touch projectors have some special requirements.

## Why Is Touch So Popular?

Simplicity is what makes touch so popular, as it takes only seconds to learn and is very natural for the user. Touch control used to be available only in very expensive computer systems, usually special-purpose ones. But the advent of inexpensive touch-controlled tablets and smartphones has made touch the new normal. When touch projectors became available, they quickly became the preferred choice for many classroom installations.

## Overview

A touch projector operates using a laser emitter. To create a laser “curtain” over the entire surface of the whiteboard, the laser emitter must be precisely aligned onto a “laser-flat” whiteboard. Improper alignment or a whiteboard that is not flat will significantly degrade the performance of the touch tracking system.

This paper explains the operation of touch projectors so these requirements can be understood, outlines the selection parameters for choosing a suitable whiteboard, and describes mounting requirements.

## Components of a Touch Projector System

**Touch projector systems have four core elements:**

- **Projector** – produces the image that is displayed on the whiteboard.
- **Laser emitter** – creates a “curtain” of invisible infrared (IR) laser light approximately 3 mm above the surface of the whiteboard.
- **Infrared camera** – detects disruptions to the laser field, i.e., the touches.
- **Whiteboard** – the whiteboard is an often unrecognized but critical system component.





### Touch Projector Technology

All interactive touch projectors use a laser emitter module to “spray” an invisible infrared (IR) laser curtain across the whiteboard. When a user puts a finger (or any object) into this field, the laser reflects off it, causing an infrared “hot spot” that the IR camera module “sees.” The camera analyzes the image in real time and reports position data over the USB connection to the teacher’s PC.

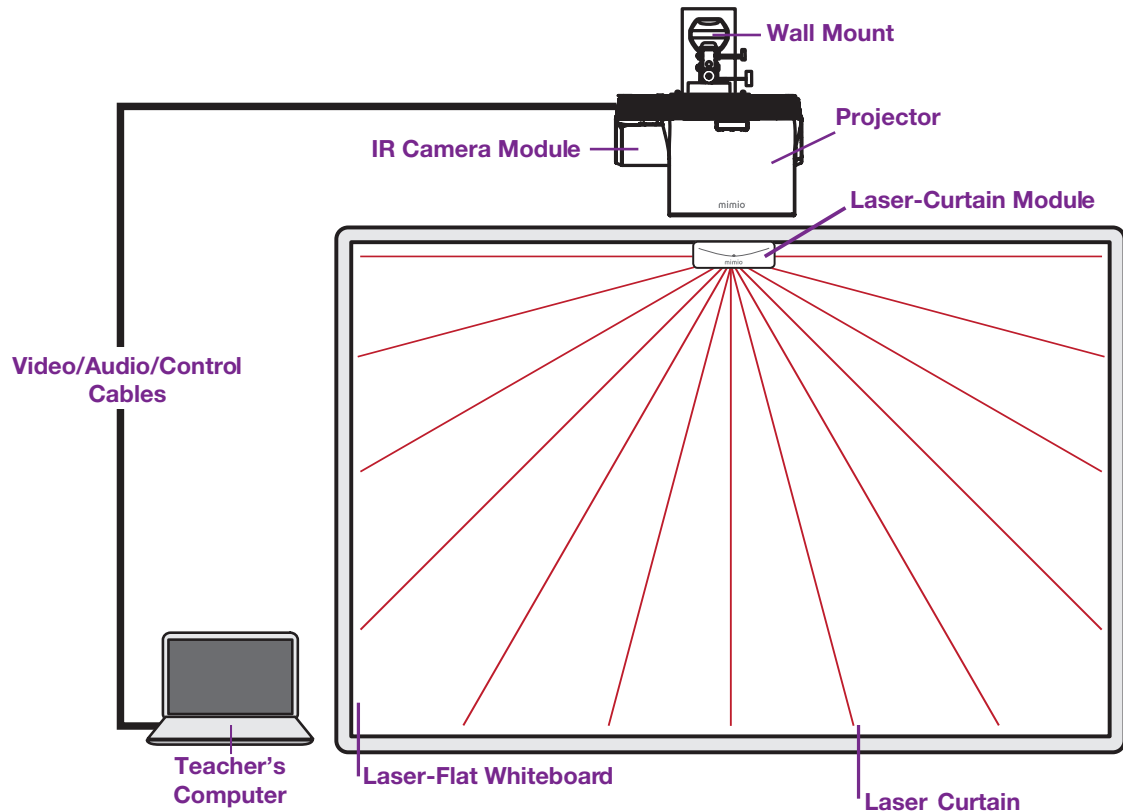

### Alignment of the Laser Emitter Module

The laser emitter module must be carefully aligned for best operation. If it is angled downward, the laser strikes the surface of the whiteboard, causing a hot spot that “confuses” the tracking system. If the laser is angled upward, the “engage depth” is too great, which causes problems when writing. The ideal is for the laser curtain to be perfectly flat across the entire surface of the whiteboard, and 2-4 mm above the surface.

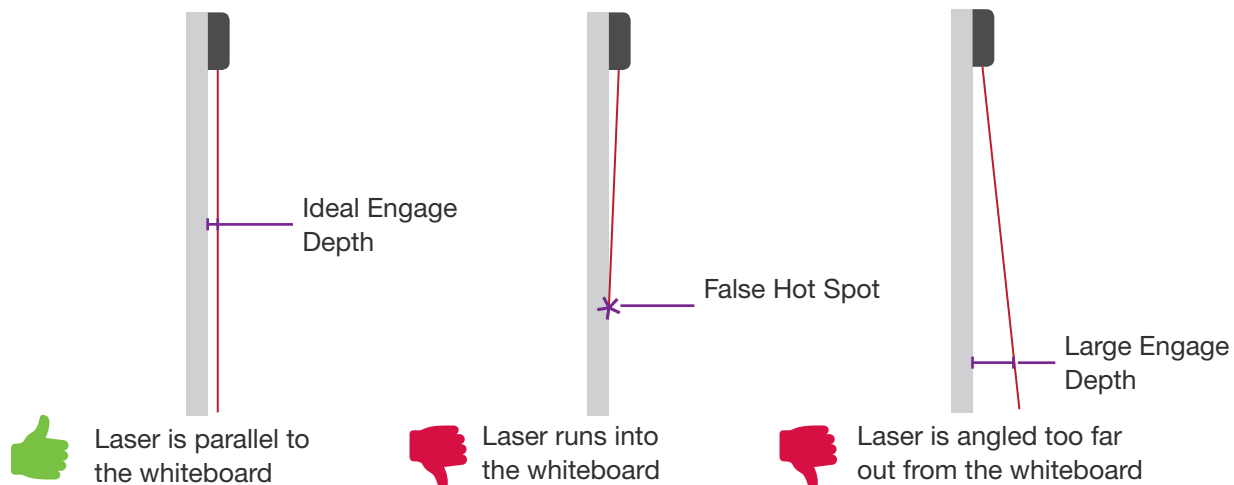



Some current touch projectors have an alignment feature that temporarily provides a visible light source to ease and speed alignment. Early models of touch projectors did not generally have this helpful feature.

### There's Flat, and There's Laser-Flat

The touch tracking system uses the IR camera to “see” IR hot spots caused by an object entering the laser curtain – any object, even the surface or frame of the whiteboard.

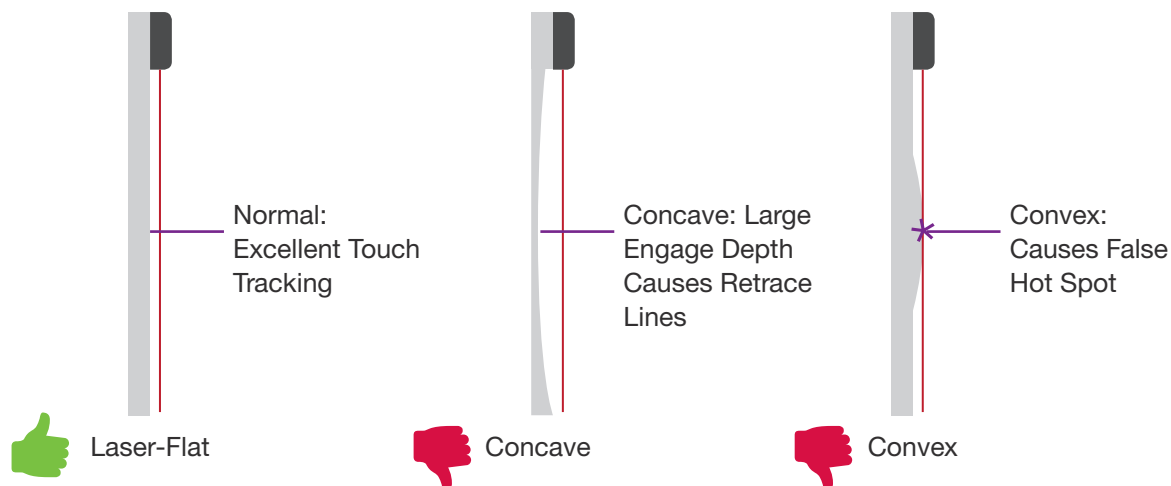

*This diagram shows the “false positive” caused by a convex whiteboard.*

A concave area can also cause significant touch tracking performance problems. In a concave area, the engage depth becomes deeper, which can cause unwanted “retrace” lines.

For example, consider writing an equals sign. The user presses a finger to the whiteboard (which causes a reflection that is detected by the IR camera), and draws the top line from left to right. The user then lifts that finger very slightly off the whiteboard, perhaps only 1-2 mm, and moves it to the left and slightly down to begin drawing the lower line from left to right. When the finger is off the board, the IR reflection ends and no line is drawn; drawing resumes when the finger is put down again and once more causes an IR reflection.



However, if the whiteboard is concave, the user may unknowingly not lift the finger far enough off the whiteboard surface to escape the laser field. In that case, the drawing continues and the result is Z instead of =. The unwanted diagonal line is a retrace line.





Both convex and concave areas can cause performance problems, but convex areas are much more of a problem. The whiteboard must be flat  $\pm 3$  mm from edge-to-edge and corner-to-corner. Only a small percentage of existing classroom whiteboards can meet this specification. There's flat and there's "laser-flat."

### Flat at the Factory Does Not Guarantee Flat on Your Wall

There are three reasons why a whiteboard that was flat when it left the factory might not be flat on your wall.

- Warping during shipping. Traveling in the back of a truck can be rough on a whiteboard, particularly when the crew is under pressure to get that truck emptied and back to the garage. When multiple whiteboards are shipped together, they are usually packed on a pallet and damage is uncommon. Problems are more frequently encountered in single-unit shipments. Palletization or "white glove" shipping can help to avoid problems in single-unit shipments.
- Warping caused by improper installation. An installer might assume that the goal is to make sure "everything is nice and tight." However, torquing a flat whiteboard down onto a non-flat wall will likely turn that flat whiteboard into a non-flat whiteboard.
- Warping from heat or humidity. A whiteboard with dissimilar front and back panels or an absorbent core can warp due to heat or humidity. This is explained in more detail below.

### Is My Whiteboard Flat Enough?

Measuring flatness to a tolerance of  $\pm 3$  mm from edge-to-edge and corner-to-corner on a whiteboard as large as 110 inches diagonal can be difficult. A straightedge that long is rare, and experience has shown that even high-quality 72-inch straightedges are not always straight to the required  $\pm 3$  mm tolerance. Specialized tools to measure the flatness of large areas are costly and not readily available.

**Need to get a whiteboard flatness tester?** Please contact our Customer Care team at [customer care@mimio.com](mailto:customer care@mimio.com) for assistance.

### Choosing and Installing a Whiteboard

The requirements for choosing and installing a whiteboard include being sure that the whiteboard is flat to begin with and making sure that it stays that way through shipment, installation, and its lifetime on the wall. There is more involved than just flatness, though flatness is absolutely critical.

### Matte or Gloss Finish

The whiteboard serves two purposes. It will spend some of its life as a projection surface, and the rest as a plain old whiteboard being used with dry erase markers.

In the days of long- or medium-throw projectors, many experts recommended using a matte surface to prevent reflected bright spots from hitting the students





in the eyes. The drawback of a matte finish, however, is the loss of apparent resolution: projections just do not look as sharp. A second drawback is that many matte surfaces do not erase well, and the resulting ghosting can typically only be eliminated with harsh chemicals.

The advent of ultra-short-throw projectors has made such reflections a thing of the past in most installations, and has opened the door to whiteboards with a gloss finish. Choosing between gloss and matte finish is now primarily a matter of preference.

### Surface Material

Many consider porcelain-on-steel to be the ultimate whiteboard surface because of its incredible durability and cleaning ease. Porcelain-on-steel generally comes with the burden of higher price and weight.

Powder-coated steel is a lower-priced option in many areas. It has excellent durability and is easily cleaned.

Paint-on-steel or paint-on-aluminum whiteboards cost even less than powder-coated whiteboards, but they are less durable and can be difficult to clean.

### Construction

A whiteboard is a sandwich composed of the white surface layer glued to a solid or honeycomb core. A high-quality whiteboard also has a rear panel made of the same material as the front panel.

The choice between a solid and a honeycomb core is primarily about weight, honeycomb being very much lighter. A solid core made of a potentially absorbent material such as medium-density fiberboard (MDF) could possibly cause warping in high-humidity environments. Honeycomb cores are plastic and are thus unaffected by humidity.

### Side View of a Whiteboard

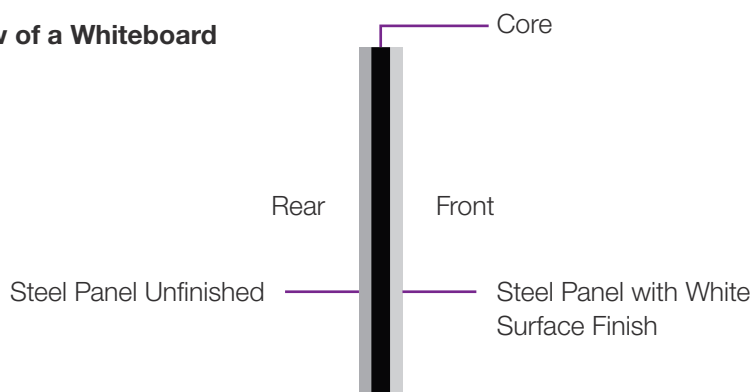

The rear panel serves two purposes. First, it seals the system to deter moisture penetration. Second, it adds strength to counteract any tendency to warp. It is important that the rear panel be of the same material as the front panel so that heat will affect them identically. Dissimilar materials can respond differently to heat, placing different stresses on the front and rear, which causes warping to occur.





### Framed or Unframed

As explained above, reflections can cause false positives that “confuse” the touch tracking system. A frame is likely to be a reflector and therefore is not recommended. If a framed board is chosen, the frame should extend above the surface of the whiteboard as little as possible. It is also good practice not to allow the projected image to extend all the way to the edge of the white area. Common practice is a guard band of 2-3 inches.

### Interference from Whiteboard Frame

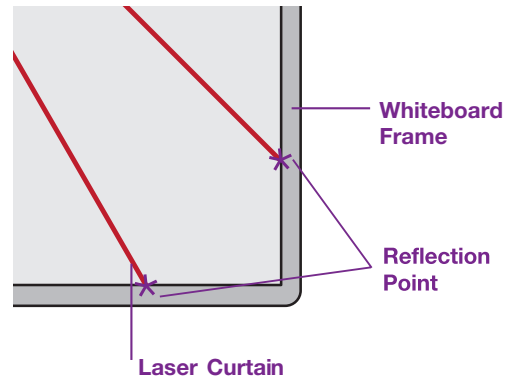

### Pen Tray

A pen tray is also a potential source of reflections. The large width and depth of most pen trays make them problematic. Use of a pen tray is not recommended.

### Size

Since whiteboards for touch projectors can serve double-duty as regular dry erase boards, they no longer take away whiteboard space (as many older touchboards did). Plus, since touch projectors can make interactive images as large as 100 inches – a feat likely to be unaffordable in touch LED displays for many years to come – it usually makes sense to “go big.”

### Weight

The weight of the whiteboard is usually an issue only with regard to shipping and installation costs.

### Magnets, Posters, Plastic Pen Holders, and All Manner of Stick-On Labels

This is a subject that has nothing at all to do with the whiteboard, and everything to do with the touch projector’s performance. It is a rare teacher who does not have student work, posters, instructional or motivational posters, and announcements attached to virtually every flat surface.

Any whiteboard used with a touch projector must always be pristine. One might respond, “But it’s just a little sticker, and it’s cute!” That may be true, but when the glue on the sticker starts to curl upwards, it quickly becomes an IR reflector, “confusing” the touch tracking system.

### Mounting System

The whiteboard must be securely mounted at top and bottom, so it does not “bounce” when touched. As mentioned above, it is also important that the whiteboard still be flat after having been mounted.

Most whiteboards are mounted on walls. If the wall itself is not flat (and many are very “non-flat”), care must be taken not to deform the whiteboard during







installation. One of the most reliable methods for a solid installation that avoids deforming the whiteboard is the “French cleat,” shown below. This is a method often chosen to hang kitchen cabinets, because it is fast, simple, and very strong. Once the whiteboard has been hung on the French cleat, the bottom can be secured using an L-bracket, as shown.

### French Cleat Installation

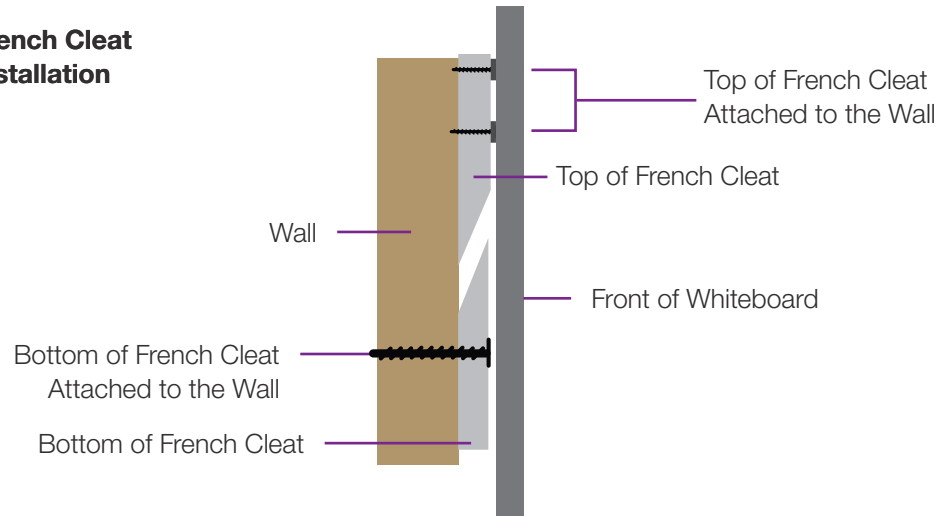

### Conclusion

Touch projector systems bring great ease of use to the classroom. The whiteboard is as much a part of that system as the projector itself. Choosing the right whiteboard and properly installing it are key to the operational excellence that will drive teacher use.

### About the Author

Stevan Vigneaux is director of product management at Mimio. Stevan holds a degree in electrical engineering from Boston’s Northeastern University, and has written numerous papers for professional journals.





mimio®