

# EST04 Quick Start Guide

1. Installation (Please refer to the Installation and Operation Manual for details)

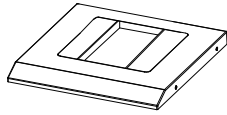

A -The Base  
1pcs

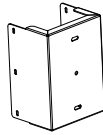

B- Lock wall bracket  
1pcs



C- Lifting Column  
1pcs

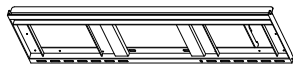

D- Wall Mount  
1pcs

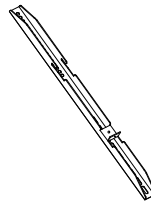

H-Hanging Bar  
2pcs



I -Control Pad  
1pcs



J- AC power cable  
1pcs



K- USB Cable  
1pcs



L- AC Power Transfer Cable  
1pcs

- A- The Base-1PCS
- B- Lock wall bracket-1PCS
- C- Lifting Column-1PCS
- D- Wall Mount-1PCS
- H- Hanging Bar-2PCS
- I- Control Pad-1PCS
- J- AC Power Cable-1PCS
- K- USB Cable-1PCS
- L- AC Power Transfer Cable -1PCS

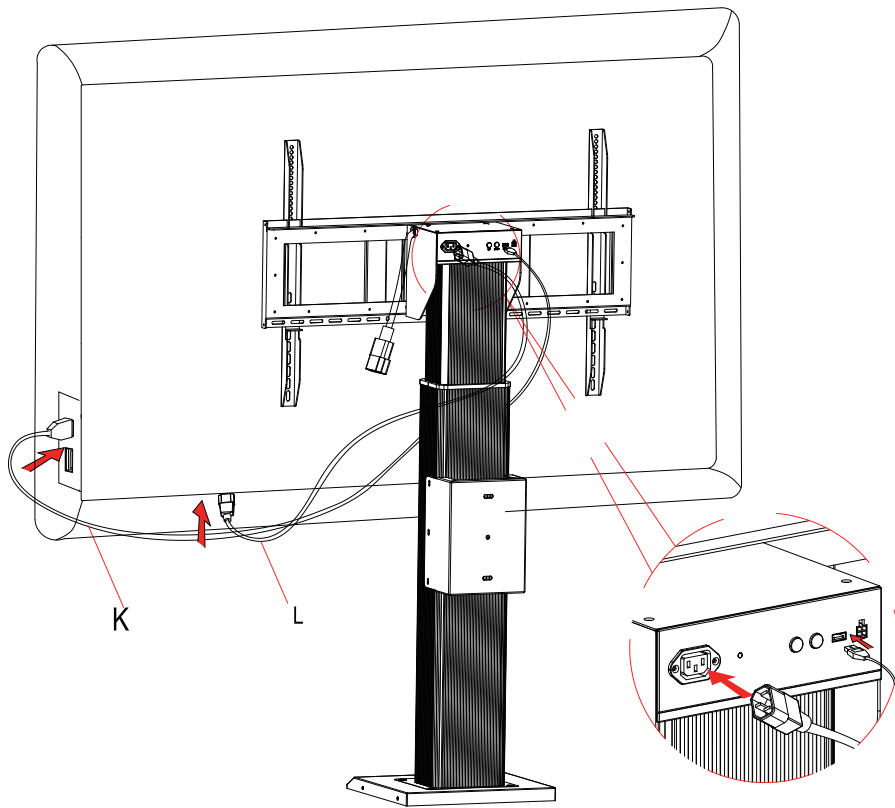
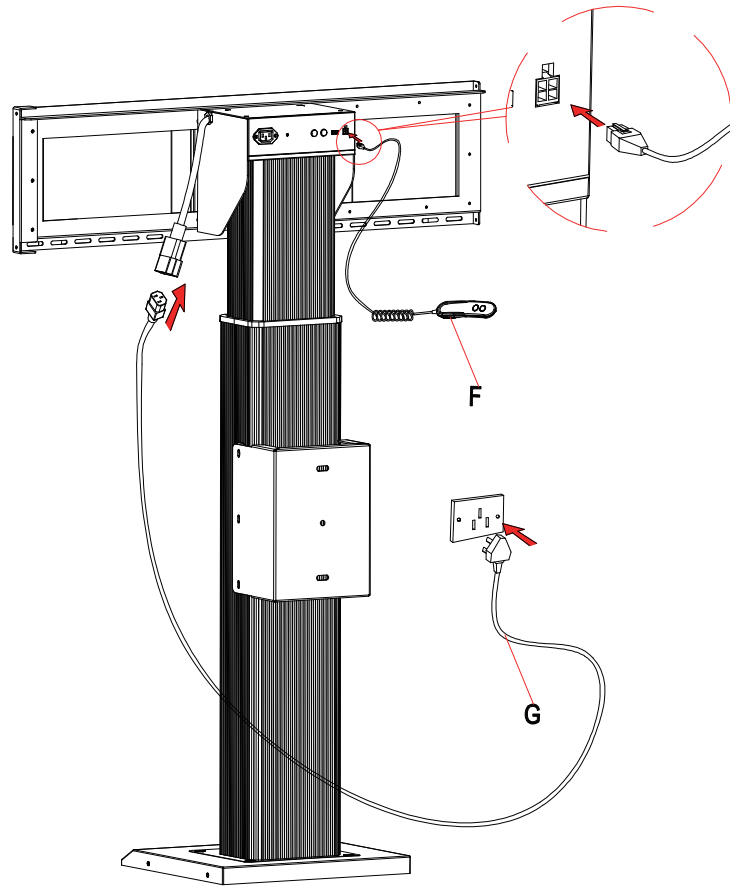

## 2.Working Mode

### 2-1.Control the Control Panel

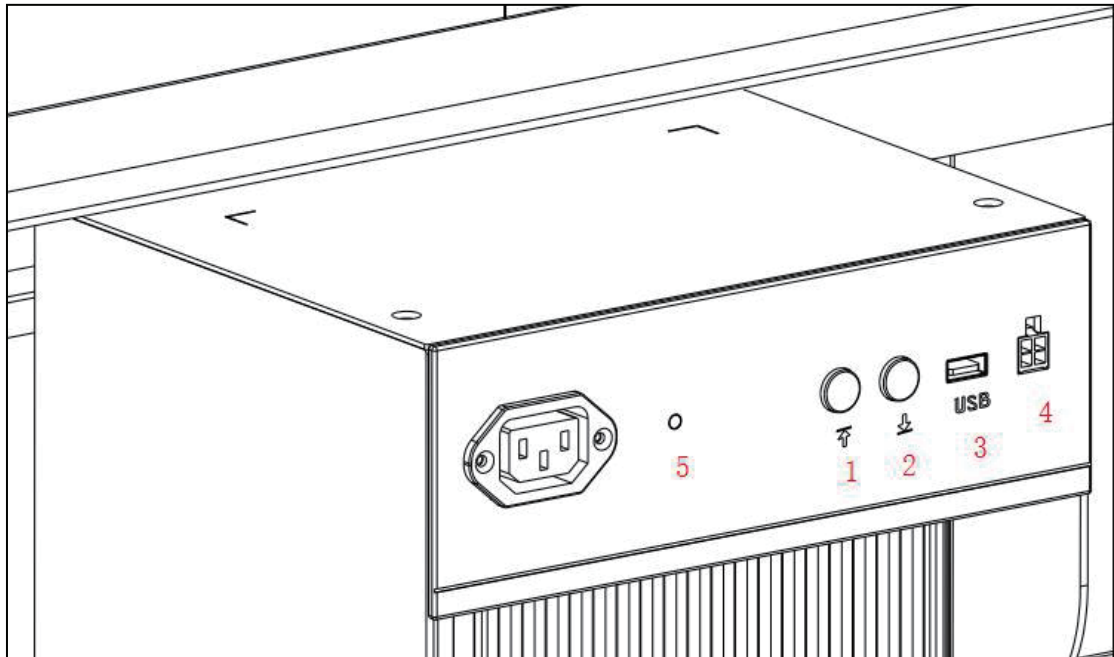

1- ↑ Key (Control the rise of the Electric Stand)

2- ↓ Key(Control the fall of the Electric Stand)

3- USB Interface (Connect with USB Transferable Cable(H), connect the Interactive Flat Panel)

4- Control Pad Interface(Connect with the Control Pad (I) )

5- Indicator Light (The standby state is red, and it turns blue when it is working.)

#### NOTE:

When the Electric Stand is powered on, after the "deep" of the buzzer, the Electric Stand can be used.

### 2-2. Control the Control Pad

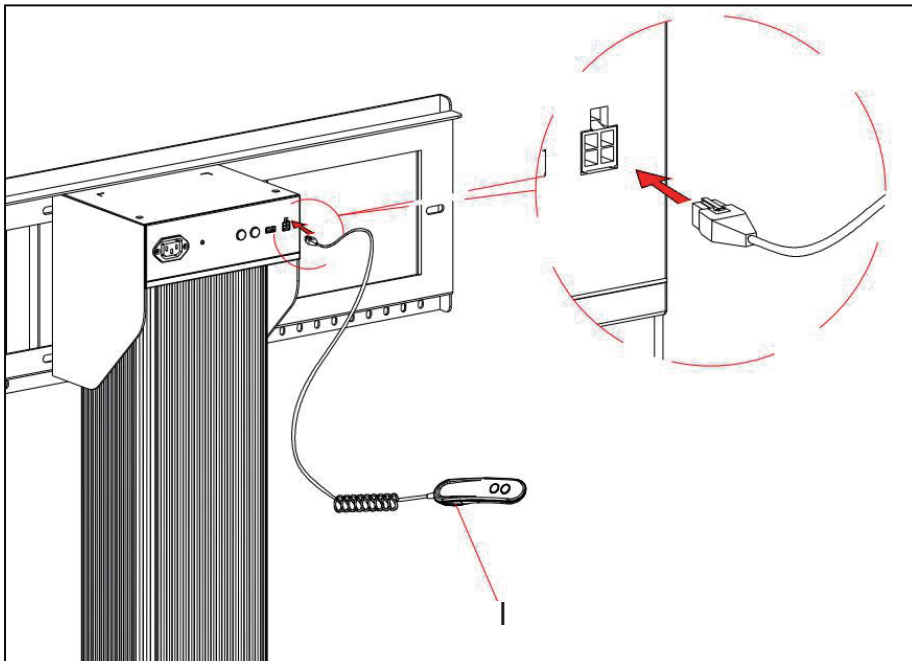

Connect the Control Pad to the interface on the lift column control panel.

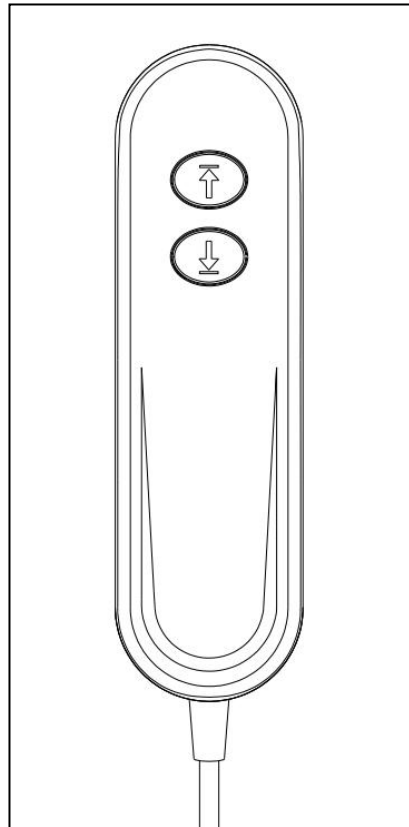

There are two buttons on the Control Pad, corresponding to the UP ( ↑ Key) and DOWN ( ↓ key) of the Control Panel.

### 2-3.Intelligent Panel software control

First, ensure that the Intelligent Panel is connected with the Electric Stand by USB transferable Cable(H).

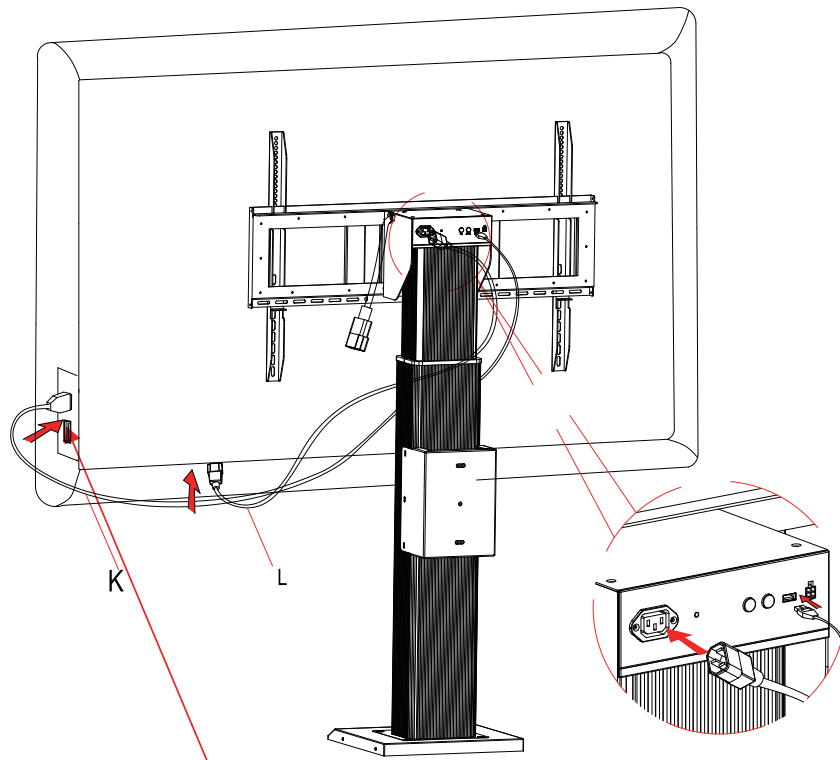

Second, turn on the Intelligent Panel, the sidebar of the Intelligent Panel will display the control button of the Electric Stand. (As shown in figure).

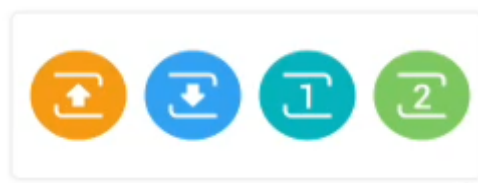
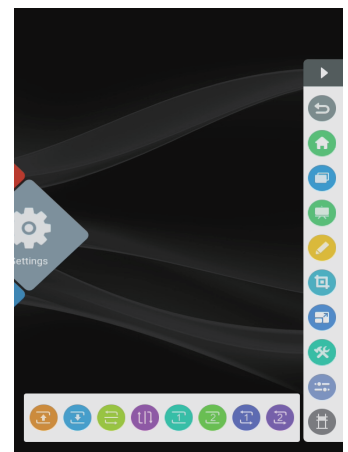
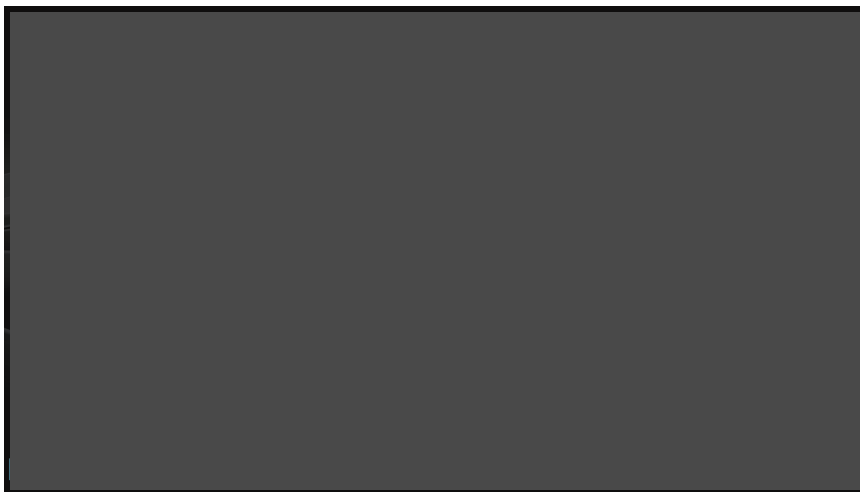

The buttons in the figure are from left to right: Up, Down, 3 position memory functions, Stop

The "UP" Key in the figure can control the rise of the Electric Stand, and the "DOWN" Key controls the fall of the Electric Stand;  
Position memory 1, 2: long press to save the height position, short press to move to the saved height position.

### 3. Precaution

- 1.The bearing of the Electric Stand  $\leq 100\text{kg}$ ;
- 2.When the Electric Stand is controlled by the software, the USB Cable(H) is only limited to the USB port on TV main board of the Intelligent Panel.
- 3.Every 2 hours of continuous operation of the column must ensure that there is more than 18 minutes of rest in the middle.